

## IPH10E

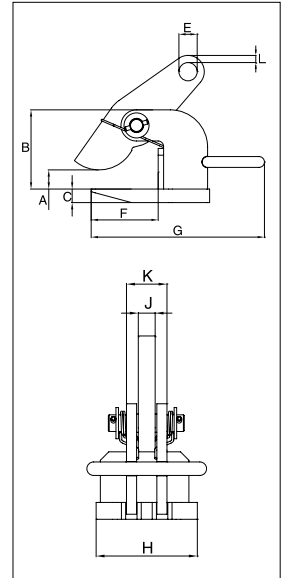

### For horizontal lifting and transfer

- Available in capacities of 2.0 thru 25 metric tons.
- Wide variety of jaw openings available: 0 to 120mm.
- Welded alloy steel body for strength and smaller size. Forged alloy, components where required.
- Equipped with handle for easy placement.
- Individually Proof Tested to 2 times the Working Load Limit with certification.
- Company name (CrosbyIP), logo, Working Load Limit and jaw opening permanently stamped on body.
- Each product is individually serialized, with the serial number and Proof Load test date stamped on body. User manual with test certificate is included with each clamp.
- Maintenance and repair spare kits are available.



### Model IPH10E

*Load Tested*

Model	Working Load Limit (Per Pair) (t)*	Stock No.	Weight Each (kg)	Dimensions (mm)									
				Jaw A	B	C	E	F	G	H	J	K	L
IPH10E	2	2703542	5.5	0 - 60	117	16	22	109	256	110	20	40	9
IPH10E	3	2703543	7.5	0 - 60	117	20	26	109	266	120	20	48	11
IPH10E	4.5	2703544	10.5	0 - 60	132	25	30	104	280	130	20	48	12
IPH10E	6	2703545	13	0 - 60	143	25	36	123	320	130	20	48	14
IPH10E	9	2703546	18.5	0 - 60	157	30	43	133	330	140	25	62	16
IPH10E	12	2703547	21.5	0 - 60	172	30	47	141	353	150	25	62	17

\* Design Factor based on EN 13155 and ASME B30.20.

### Model IPH10JE

Model	Working Load Limit (Per Pair) (t)*	Stock No.	Weight Each (kg)	Dimensions (mm)									
				Jaw A	B	C	E	F	G	H	J	K	L
IPH10JE	3	2703553	9.0	60 - 120	177	20	26	109	266	120	20	48	11
IPH10JE	4.5	2703554	12.0	60 - 120	192	25	30	104	280	130	20	48	12
IPH10JE	6	2703555	15.0	60 - 120	203	25	36	123	320	130	20	48	14
IPH10JE	9	2703556	20.5	60 - 120	217	30	43	133	330	140	25	62	16
IPH10JE	12	2703557	24.0	60 - 120	232	30	47	141	353	150	25	62	17

\* Design Factor based on EN 13155 and ASME B30.20.

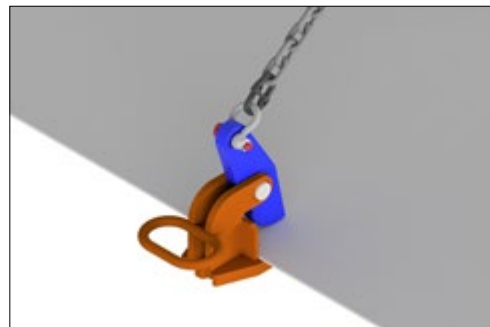
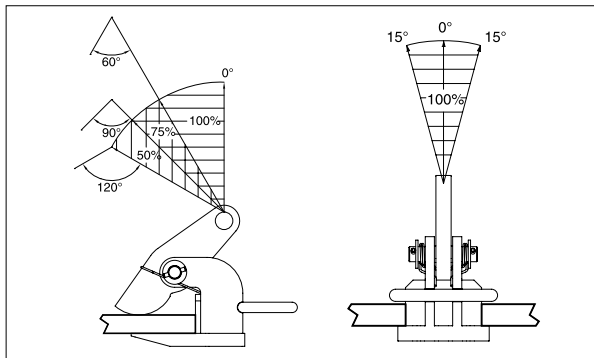

12