

## IPU10A

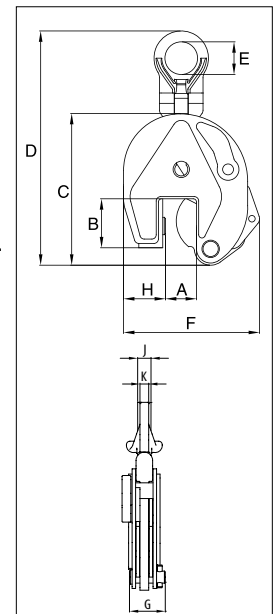

### For vertical transport of plates

- Available in capacities of 1, 2 and 6 metric tons (higher Working Load Limits are available upon request).
- Jaw openings available: 0 to 50mm.
- Welded alloy steel body for strength and smaller size. Forged alloy components where required.
- Individually Proof Tested to 2 times the Working Load Limit with certification.
- Company name (Crosby IP), logo, Working Load Limit and jaw opening permanently stamped on body.
- Each product is individually serialized, with the serial number and Proof Load test date stamped on body. User manual with test certificate is included with each clamp.
- Full 180° turning range for material transfer, turning or moving.
- Lock open, lock closed ability with latch for pretension on material and then release of material.
- Minimum WLL of 10% of Maximum WLL.
- Maintenance and repair kits are available.
- For use with materials with a plate surface hardness to 279HV10, only 5% of minimum WLL is needed.



Load Rated

### Model IPU10A

Model	Working Load Limit (t)*	Stock No.	Weight Each (kg)	Dimensions (mm)									
				Jaw A	B	C	D	E	F	G	H	J	K
IPU10A	1	2701628	2.3	0 - 20	45	139	225	40	127	42	38	-	11
IPU10A	2	2701629	8.4	0 - 35	78	201	368	70	188	64	55	-	16
IPU10A	6	2701638	25.4	0 - 50	126	302	525	80	292	84	95	44	20

\* Design Factor based on EN 13155 and ASME B30.20.

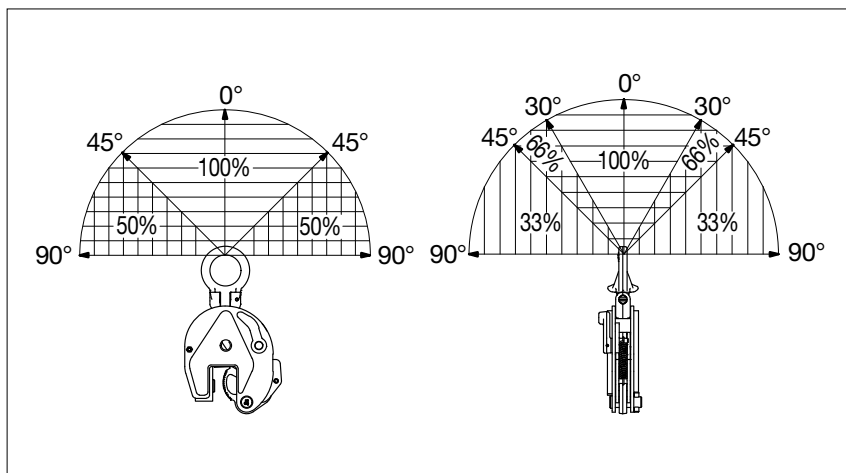

12