

Load ring weldable
suits 90°-corners for lashing
> **LRBK-FIX** <

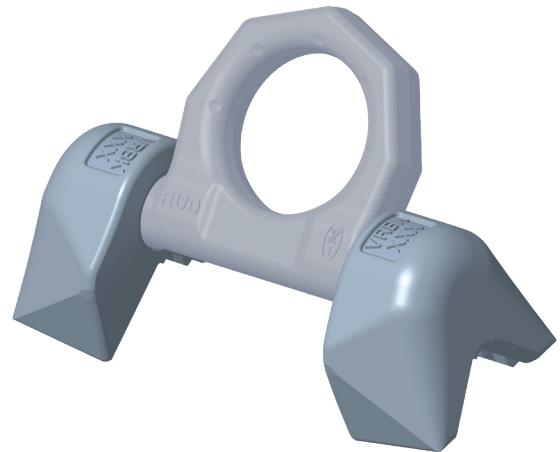

Safety instructions

This safety instruction/declaration has to be kept on file for the whole lifetime of the product and forwarded with the product.
TRANSLATION OF THE ORIGINAL SAFETY INSTRUCTION



RUD Ketten
Rieger & Dietz GmbH u. Co. KG
73428 Aalen
Tel. +49 7361 504-1370
Fax +49 7361 504-1460
slings@rud.com
www.rud.com

RUD-Art.-Nr.: 7903355 / EN / V03 / 10.022

**Load ring for 90°-corners
for lashing (weldable)**

LRBK-FIX

Herstellererklärung

Hiermit erklären wir (unterstützt durch die Zertifizierung nach ISO 9001), dass die nachfolgend bezeichnete Ausrüstung aufgrund ihrer Konzipierung und Bauart, sowie der von uns in Verkehr gebrachten Ausführung, den einschlägigen grundlegenden Sicherheits- und Gesundheitsanforderungen der Europäischen Union entspricht. Bei einer nicht mit uns abgestimmten Änderung der Ausrüstung verliert diese Erklärung ihre Gültigkeit. Weiterhin verliert diese Erklärung ihre Gültigkeit, wenn die Ausrüstung nicht entsprechend den in der Betriebsanleitung aufgezeigten bestimmungsmäßigen Fällen eingesetzt wird.

Hinweis: Beim Zurrpunkt angewendete harmonisierte Normen DIN EN ISO 12100 T1 und T2 sowie in Anlehnung an EN 1677.

Bezeichnung der Ausrüstung:
Zurrpunkt

Typ: Schweißbarer Zurrpunkt für 90° Ecken:
LRBK-FIX

Herstellerzeichen:

Declaration of the manufacturer

We hereby declare (supported by ISO 9001 certification), that the following described equipment based on the concept and design as well as the by us manufactured type corresponds to the current valid Health- and Safety Requirements of the EU. This declaration becomes invalid in case of any modifications not agreed upon with us. Furthermore this declaration becomes invalid if the equipment is not used according to this prescription.

Hint: Utilized harmonized standards for this Lashing Point DIN EN 12 100 T1 and T2 as well as EN 1677.

Designation of the equipment:

Lashing point

Type: Lashing Point Welding for 90° corners:
LRBK-FIX

Manufacturer's sign:



Before initial usage of the RUD-LRBK-FIX, please read carefully the safety instructions. Make sure that you have understood all subjected matters.

Non-observance can lead to serious personal injuries and material damage and eliminates warranty.

1 Safety instructions



ATTENTION

Wrong positioned or damaged weld-on lashing points as well as improper use can lead to injuries of persons and damage at property. Please check all lashing points carefully before every usage.

- Remove all body parts (fingers, hands, arms, etc.) out of the hazard area (danger of crushing or squeezing) during the lashing process.
- RUD lashing points LRBK-FIX must only be used by instructed and competent persons considering DGUV 109-017, and outside Germany noticing the country specific statutory regulations.
- The lashing points must not protrude in rest position over the loading platform level.
- Do not exceed the LC (Lashing Capacity) indicated on the lashing point.
- No technical modifications must be made to the LRBK-FIX.
- No persons are allowed in the danger zone.
- Damaged or worn LRBK-FIX must not be used.

2 Intended use of the LRBK-FIX

RUD-lashing points LRBK-FIX must only be used to attach lashing means.

Lashing points must not be used for lifting loads.

RUD-lashing points must only be used in the hereby specified case of operation.

3 Assembly- and instruction manual

3.1 General information

- Capability of temperature usage:
As of 07/2019: RUD-Lashing points LRBK-FIX are suitable for the temperature range from -40°C up to 400°C.
Up to 07/2019: RUD-Lashing points LRBK-FIX are suitable for the temperature range from -20°C up to 400°C.
For the use within the following temperature range, the LC (Lashing Capacity) must be reduced by the following factors:

-40°C / -20°C up to 200°C	no reduction
200°C up to 300°C	minus 10 %
300°C up to 400°C	minus 25 %

 Temperatures exceeding 400°C are prohibited!

In the unloaded state, LRBK-FIX lashing points together with the connected component can be stress relieved by heat treating (e.g. welded construction) once. Temperature: < 600°C (one hour maximum). After stress-relieving heat treatment (< 600°C), however, the spring force is no longer usable.

- RUD-Lashing points LRBK-FIX must not be used with aggressive chemicals such as acids, alkaline solutions and their vapours.

- It is recommended, that the places where the lashing points are fixed should be marked with colour.
- LRBK-FIX includes a protected positioned clamping spring, inside the weld-on block. The spring holds the weld-on blocks together with the ring and creates at the same time a radial clamping function.
- RUD-lashing points LRBK-FIX are clearly marked at the suspension ring with the permissible Lashing capacity „LC“ in daN.
- LRBK-FIX will be delivered as a complete assembled unit.

3.2 Hints for the assembly

Basically essential:

- The material construction to which the lashing point will be attached should be of adequate strength to withstand forces during lashing without deformation. The weld-on material must be suitable for welding and the contact areas must be free from dirt, oil, colour, ect. The material of the forged welding block is: S355J2+N (1.0577+N (St52-3))
- The position of the lashing points must be carried out in regard to the lashing means in such a way that unintended movement like turning or flipping of the load will be avoided.
- Consider the die ISO 15818 „Earth-moving machinery - Lifting and tying-down attachment points“.
- Determine number and position of the lashing points at vehicles according to EN 12640 resp. DIN 75410 (for RoRo-transportation acc. to EN 29367), unless the vehicles are not determined due to their design and construction for transporting specific goods with special requirements in regard of load securing.
- Determine the required, permitted Lashing Capacity acc. EN 12195-1 „Load restraining on road vehicles - Safety - Part 1: Calculation of securing forces“, acc. VDI 2700-2 „Securing of loads on road vehicles“ and acc. ISO 15818.



HINT

The Lashing Points should be arranged (depending on use) as wide as possible to use the full loading area and they should not protrude in steady position.

- Check finally the correct assembly (see chapter 4 Inspection / Repair / Disposal).

3.3 Hints for the welding

The welding should only be carried out according to DIN EN ISO 9606-1 or AWS Standards by an authorized and certified welder.

Verification of the used weld-on material must be checked with the supplier of the welding electrodes.



HINT

- Never weld at the quenched and tempered ring!
- Weld all seams at the same temperature.

- 1 Check before initial appending of the LRBK-FIX, the position of the weld-on blocks to each other, that means the base area must be at the same level.
- 2 Append weld-on blocks.
- 3 Check function of the ring.
The ring must be able to pivot 270°. If necessary please correct.

- 4 Once appending and checking of the function have been carried please finish the root run. The outside positioned weld layers must be carried out first. The described welding sequences must be observed compulsive.
- 5 Begin at starting point S1 and weld subsequently the sections 1-4 (Pic. 1).
- 6 Then weld the opposite side identically (starting point S2 and chapter 5-8).
- 7 Afterwards close the rot pass at the inside areas (chapter 9-10 and 11-12).

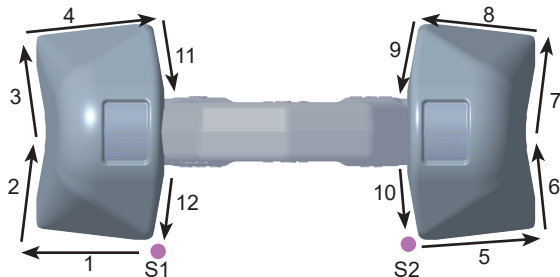

Pic. 1: Welding sequence of the root run (S=Starting point)

- 8 Finally please let the parts cool down.
- 9 Remove any welding mistakes and dirt at the root weld before applying the cover weld seams.
- 10 Subsequently please weld the closure welds. Start at the inside. The described welding sequences must be observed compulsive. Chose type and dimension of weld seam from Pic. 3 and Table 2.
- 11 Begin at starting point S3 and weld subsequently the chapters 1-6 (Pic. 2)
- 12 Please weld then the opposite side identically. (tarning point S4 and chapter 7-12)



HINT

Please adhere the requested weld seam thickness in any cases. Any change can result in a malfunction of the ring latch.

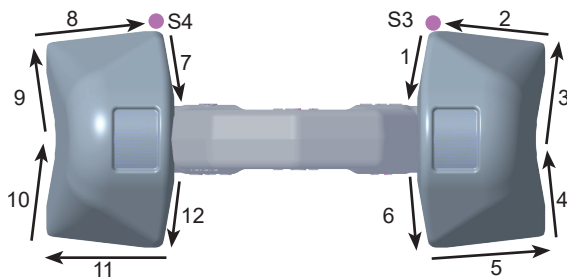

Pic. 2: equence of closure welding (S=Starting point)

- 13 Please check by a competent person after welding the ongoing usage of the weld-on lashing point (see chapter 4 Inspection / Repair / Disposal).



HINT

By the position of the weld-seam (HY-weld circumferential) the following requirements will be observed: DIN 18800 steel constructions requires: at outdoor buildings or when strong corrosion must be expected weld seams must be carried out as continuous fillet weld seams.

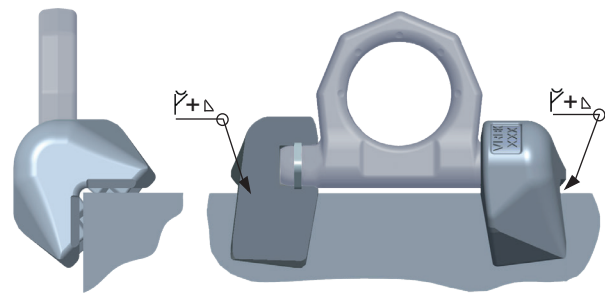

Pic. 3: weld seam

3.4 User instruction

- Check frequently and before each initial operation the whole lashing point in regard of linger ability as a lashing mean, regarding corrosion, wear, deformation etc. (see chapter 4 Inspection / Repair / Disposal).



ATTENTION

Wrong positioned or damaged weld-on lashing points as well as improper use can lead to injuries of persons and damage at property. Please check all lashing points carefully before every usage.

- Please check carefully the wear indicator markings of the weld-on lashing point (see Pic. 4):

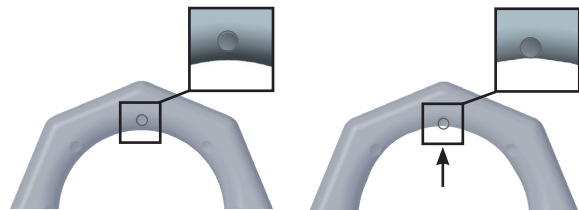

Usage permitted:

no wear marks visible

Use prohibited:

Replacement criteria reached.

Material all the way down to the wear lenses has gone.

Pic. 4: Wear indicators

- Please note that the lashing mean must be free moveable in the LRBK-FIX. When lashing means (f.e. lashing chain) are hinged or unhinged, no pinching, shearing or joint spots must occur during the handling.
- Avoid damage of lashing means resulting from sharp edges.
- Lashing points must not be used for lifting loads.

4 Inspection / Repair / Disposal

4.1 Hints for periodical inspections

The operator must determine and specify the nature and scope of the required tests as well as the periods of repeating tests by means of a risk assessment (see sections 4.2 and 4.3).

The continuing suitability of the lashing point must be checked at least 1x year by an expert.

Depending on the usage conditions, f.e. frequent usage, increased wear or corrosion, it might be necessary to check in shorter periods than one year. The inspection has also to be carried out after accidents and special incidents.

4.2 Test criteria for the regular visual inspection by the user

- Completeness of the lashing point
- Complete and readable marking of Lashing Capacity as well as manufacturer sign
- Deformation at load bearing components like base body and ring.
- Mechanical damage, like strong notches, especially in areas where tensile stress occurs.

4.3 Additional test criteria for the competent person / repair worker

- Reduction of cross-section due to wear >10 %
- Evidence of corrosion (pittings)
- Any other damage
- Further checks may be required, depending on the result of the risk assessment (e.g. testing for cracks in load-bearing parts / at weld seam).

4.4 Disposal

Dispose worn out components / attachments or packaging according to the local waste removal requirements.

Europe, USA, Asia, Australia, Africa

Baustähle, niedrig legierte Stähle EN 10025,
Mild steels, low alloyed steel EN 10025

MIG / MAG (135) Gas shielded wire welding (135)	DIN EN ISO 14341: G4Si1 (G3Si1) Z.B. PEGO G4Si1
E-Hand Gleichstrom (111, =) Stick Electrode direct current	DIN EN ISO 2560-A: E 42 6 B 3 2 H10 DIN EN ISO 2560-A: E 38 2 B 1 2 H10 z.B. PEGO B Spezial*/ PEGO BR Spezial*
E-Hand (Wechselstrom 111, ~) Stick Electrode alternating current	DIN EN ISO 2560-A: E 38 2 RB 1 2 DIN EN ISO 2560-A: E 42 0 RC 1 1 z.B. PEGO RC 3 / PEGO RR B 7 Alternativ: DIN EN ISO 3581: E 23 12 2 L R 3 2 z.B. PEGO 309 MoL
WIG (141) TIG Tungsten arc welding	DIN EN ISO 636-A: W 3 Si 1 (W2 Si 1) DIN EN ISO 636-A: W 2 Ni 2 z.B. PEGO WSG 2 / PEGO WSG2Ni2



HINT

Please note the corresponding user hint in regard of the welding filler materials and the drying requirements*.

Table 1: Welding procedure + Welding filler metals

Type	size	length	volume
LRBK-FIX 8,000	HY 4 + a 3	approx. 124 mm	approx. 3.1 cm ³
LRBK-FIX 13,400	HY 5 + a 3	approx. 144 mm	approx. 4.9 cm ³
LRBK-FIX 20,000	HY 8 + a 3	approx. 184 mm	approx. 13.4 cm ³

Table 2: Weld seam (weld-on block)

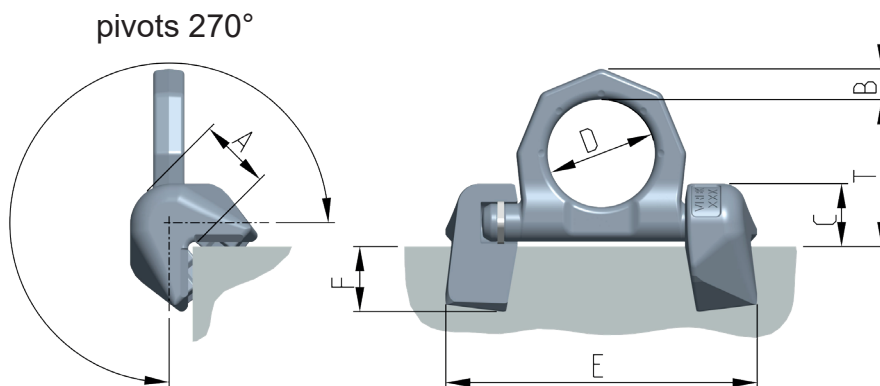

Pic. 5: Dimensioning

Type	LC [daN]	A [mm]	B [mm]	C [mm]	D [mm]	E [mm]	F [mm]	T [mm]	weight [kg/pc.]	Ref.-No. complete	Ref.-No. ring	Ref.-No. weld block
LRBK-FIX 8.000 Oktagon	8,000	32	14	28	48	140	29	65	1.0	7903056	7910471	7910942
LRBK-FIX 8,000*		32	14	28	48	141	29	65			7999297	7901699
LRBK-FIX 13.400 Oktagon	13,400	40	19	35	60	181	33	84	2.1	7903057	7910472	7910943
LRBK-FIX 13,400*		40	20	35	60	181	34	84			7999298	7901700
LRBK-FIX 20.000 Oktagon	20,000	52	20	46	65	210	46	94	4.4	7903058	7910473	7910944
LRBK-FIX 20,000*		52	22	46	65	212	46	94			---	7901901

Table 3: Dimensioning

* Model in round design - as long as stock lasts

Subject to technical alterations