

Lashing point - Load Ring weldable > LRBS-FIX <



Safety instructions

This safety instruction/declaration has to be kept on file for the whole lifetime of the product and forwarded with the product.
TRANSLATION OF THE ORIGINAL SAFETY INSTRUCTION



RUD Ketten
Rieger & Dietz GmbH u. Co. KG
73428 Aalen
Tel. +49 7361 504-1370
Fax +49 7361 504-1460
sling@rud.com
www.rud.com

RUD-Art.-Nr.: 7901036-EN / V03 / 11.022

Lashing point
Load Ring weldable

> LRBS-FIX <

Herstellererklärung

Hiermit erklären wir (unterstützt durch die Zertifizierung nach ISO 9001), dass die nachfolgend bezeichnete Ausrüstung aufgrund ihrer Konzipierung und Bauart, sowie der von uns in Verkehr gebrachten Ausführung, den einschlägigen grundlegenden Sicherheits- und Gesundheitsanforderungen der Europäischen Union entspricht. Bei einer nicht mit uns abgestimmten Änderung der Ausrüstung verliert diese Erklärung ihre Gültigkeit. Weiterhin verliert diese Erklärung ihre Gültigkeit, wenn die Ausrüstung nicht entsprechend den in der Betriebsanleitung aufgeführten bestimmungsmäßigen Fällen eingesetzt wird.

Hinweis: Beim Zurrpunkt angewendete harmonisierte Normen DIN EN ISO 12100 T1 und T2 sowie in Anlehnung an EN 1677.

Bezeichnung der Ausrüstung:
Zurrpunkt

Type: Ringbock schweißbar

Herstellerzeichen:

Declaration of the manufacturer

We hereby declare (supported by ISO 9001 certification), that the following described equipment based on the concept and design as well as the by us manufactured type corresponds to the current valid Health- and Safety Requirements of the EU. This declarations becomes invalid in case of any modifications not agreed upon with us. Furthermore this declaration becomes invalid if the equipment is not used according to this prescription.

Hint: Utilized harmonized standards for this Lashing Point DIN EN 12 100 T1 and T2 as well as EN 1677.

Designation of the equipment:
Lashing point

Type: Load Ring weldable

Manufacturer's sign:



Before initial usage of the RUD LRBS-FIX, please read carefully the safety instructions. Make sure that you have understood all subjected matters.

Non-observance can lead to serious personal injuries and material damage and eliminates warranty.

1 Safety instructions



ATTENTION

Wrong positioned or damaged weld-on lashing points as well as improper use can lead to injuries of persons and damage at property.

Please check all lashing points carefully before every usage.

- Keep all body parts like fingers, hands, arms, etc. out of the hazardous area during the lashing operation.
- RUD Lashing points LRBS-FIX must only be used by instructed and competent persons considering DGUV 109-017 and outside Germany noticing the country specific statutory regulations.
- Do not exceed the LC (Lashing Capacity) indicated on the lashing point.
- Attention: When suspension ring pivots there is a risk of pinching.
- The lashing points must not protrude in rest position over the loading platform level.
- Any technical modifications at the LRBS-FIX are prohibited.
- Keep persons out of the hazardous area.
- Damaged or worn LRBS-FIX must no longer be used.

2 Intended use of the LRBS-FIX

RUD Lashing points LRBS-FIX must only be used to attach lashing means.

In general, lashing points must not be used for lifting!

RUD Lashing points must only be used in the hereby specified case of operation.

3 Assembly- and instruction manual

3.1 General information

- Capability of temperature usage:

As of 07/2019: RUD Lashing points LRBS-FIX are suitable for the temperature range from -40°C up to 400°C.

Up to 07/2019: RUD Lashing points LRBS-FIX are suitable for the temperature range from -20°C up to 400°C.

For the use within the following temperature range, the LC (Lashing Capacity) must be reduced by the following factors:

-40°C / -20°C up to 200°C no reduction
 200°C up to 300°C: by -10 % and
 300°C up to 400°C: by -25 %

Temperatures exceeding 400°C are prohibited

In the unloaded state, LRBS-FIX Lashing points together with the connected component can be stress relieved by heat treating (e.g. welded construction) once. Temperature: < 600°C (one hour maximum). After stress-relieving heat treatment (< 600°C), however, the spring force is no longer usable.

- RUD Lashing points LRBS-FIX must not be used with aggressive chemicals such as acids, alkaline solutions and their vapours.
- It is recommended, that the places where the lashing points are fixed should be marked with colour.
- LRBS-FIX includes a protected positioned clamping spring, inside the weld-on block. The spring holds the weld-on blocks together with the ring and creates at the same time a radial clamping function.
- RUD Lashing points LRBS-FIX are clearly marked at the suspension ring with the permissible Lashing capacity „LC“ in daN.
- LRBS-FIX will be delivered as a complete assembled unit.

3.2 Hints for the assembly

Basically essential:

- The material construction to which the lashing point will be attached should be of adequate strength to withstand forces during lashing without deformation. The weld-on material must be suitable for welding and the contact areas must be free from dirt, oil, colour, ect.

The material of the forged welding block is: S355J2+N (1.0577+N (St52-3))

- The position of the lashing points must be carried out in regard to the lashing means in such a way that unintended movement like turning or flipping of the load will be avoided.
- Consider the die ISO 15818 „Earth-moving machinery - Lifting and tying-down attachment points“.
- The quantity and the arrangement of the Lashing Points on vehicles have to be determined acc. EN 12640 or EN 75410 (for RoRo traffic; Roll-on - Roll-off) as long as the vehicles are not designated acc. their design and mechanism for the transport of specific goods with special demands for load securing.
- Determine the required, permitted Lashing Capacity acc. EN 12195-1 „Load restraining on road vehicles - Safety - Part 1: Calculation of securing forces“, acc. VDI 2700-2 „Securing of loads on road vehicles“ and acc. ISO 15818.



HINT

The Lashing Points should be arranged (depending on use) as wide as possible to use the full loading area and they should not protrude in steady position.

- Check finally the correct assembly (see chapter 4 *Inspection / Repair / Disposal*).

3.3 Hints for the welding

The welding should only be carried out according to DIN EN ISO 9606-1 or AWS Standards by an authorized and certified welder.

Verification of the used weld-on material must be checked with the supplier of the welding electrodes.



HINT

- Never weld at the quenched and tempered ring!
- Weld all seams at the same temperature.

- 1 Check before initial appending of the LRBS-Fix, the position of the weld-on blocks to each other, that means the base area must be at the same level.
- 2 Append weld-on blocks.
- 3 Check function of the ring. The ring must be able to pivot 180°. If necessary please correct.
- 4 Remove any welding mistakes and dirt at the root weld before applying the cover weld seams.
- 5 Weld blocks on (HY-weld circumferential). Choose type of weld seam and size according to *Pic. 2* and *Table 2*.
- 6 Please check by a competent person after welding the ongoing usage of the weld-on lashing point (see chapter 4 *Inspection / Repair / Disposal*)



HINT

By the position of the weld-seam (HY-weld circumferential) the following requirements will be observed: DIN 18800 steel constructions requires: at outdoor buildings or when strong corrosion must be expected weld seams must be carried out as continuous fillet weld seams.

3.4 Hints for the usage

- Check frequently and before each initial operation the whole lashing point in regard of linger ability as a lashing mean, regarding corrosion, wear, deformation etc. (see chapter 4 *Inspection / Repair / Disposal*).



ATTENTION

Wrong positioned or damaged weld-on lashing points as well as improper use can lead to injuries of persons and damage at property. Please check all lashing points carefully before every usage.

- Please check carefully the wear indicator markings of the weld-on lashing point (see *Pic. 1*):

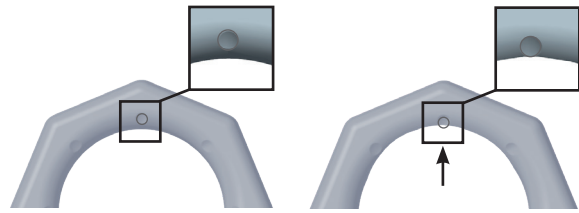

Usage permitted:

no wear marks visible

Use prohibited:

Replacement criteria reached. Material all the way down to the wear lenses has gone.

Pic. 1: Wear indicators

- Please note that the lashing mean must be free moveable in the LRBS-FIX. When lashing means (f.e. lashing chain) are hinged or unhinged, no pinching, shearing or joint spots must occur during the handling.
- Avoid damage of lashing means resulting from sharp edges.
- Lashing points must not be used for lifting loads.

4 Inspection / Repair / Disposal

4.1 Hints for the regularly inspection

The operator has to determine and dictate the necessary inspection periods and the deadlines by a risk assessment (see sections 4.2 and 4.3).

The persisting appropriateness of the lashing point must be checked by a competent person (auditor) at least once per year.

Depending on the conditions of use e.g. frequent use, increased wear or corrosion, it may be necessary to carry out inspections at shorter intervals than once per year. A verification is also required following damage and after special events.

The operator must specify the test cycles.

4.2 Inspection criteria for the regularly examination carried out by the operator

- Completeness of the lashing point
- Complete and readable marking of Lashing Capacity as well as manufacturer sign.
- Deformation at load bearing components like base body and Ring.
- Mechanical damage, like strong notches, especially in areas where tensile stress occurs.

4.3 Additional inspection criteria for the competent person resp. auditor

- Reduction of cross-section due to wear >10 %
- Evidence of corrosion (pitting)
- Additional inspections may be necessary depending on the result of the risk assessment (e.g. incipient cracks at load bearing parts/weld seam).

4.4 Disposal

Dispose worn out components / attachments or packaging according to the local waste removal requirements.

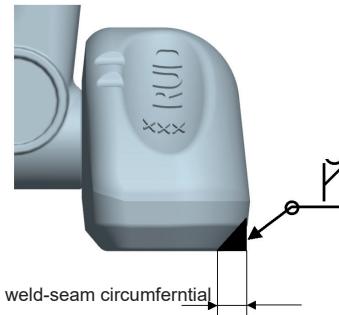

Pic. 2: HY-Naht / HY-weld seam

5 Tables / Overview

	Europe, USA, Asia, Australia, Africa
	Baustähle, niedrig legierte Stähle EN 10025, Mild steels, low alloyed steel EN 10025
MIG / MAG (135) Gas shielded wire welding (135)	DIN EN ISO 14341: G4Si1 (G3Si1) Z.B. PEGO G4Si1
E-Hand Gleichstrom (111, =) Stick Electrode direct current	DIN EN ISO 2560-A: E 42 6 B 3 2 H10 DIN EN ISO 2560-A: E 38 2 B 1 2 H10 z.B. PEGO B Spezial* / PEGO BR Spezial*
E-Hand (Wechselstrom 111, ~) Stick Electrode alternating current	DIN EN ISO 2560-A: E 38 2 RB 1 2 DIN EN ISO 2560-A: E 42 0 RC 1 1 z.B. PEGO RC 3 / PEGO RR B 7 Alternativ: DIN EN ISO 3581: E 23 12 2 L R 3 2 z.B. PEGO 309 MoL
WIG (141) TIG Tungsten arc welding	DIN EN ISO 636-A: W 3 Si 1 (W2 Si 1) DIN EN ISO 636-A: W 2 Ni 2 z.B. PEGO WSG 2 / PEGO WSG2Ni2

Table 1: Welding procedure + Welding filler metals



HINT

Please note the corresponding user hint in regard of the welding filler materials and the drying requirements*.

Type	size	length	volume
LRBS-FIX 8,000	HY 3	2 x 154 mm	approx. 1.4 cm ³
LRBS-FIX 13,400	HY 5	2 x 214 mm	approx. 5.35 cm ³
LRBS-FIX 20,000	HY 6	2 x 252 mm	approx. 9 cm ³
LRBS-FIX 32,000	HY 9	2 x 341 mm	approx. 27 cm ³

Table 2: Weld seam (weld-on block)

Type LRBS-FIX (complete)	LC [daN]	A [mm]	B [mm]	C [mm]	D [mm]	E [mm]	F [mm]	T [mm]	weight [kg/pc.]	Ref. no complete
LRBS-FIX 8,000 Oktagon	8.000	60	14	38	48	132	70	74	0,93	7999303
LRBS-FIX 8,000*		60	14	39	48	132	69	74	0,94	
LRBS-FIX 13,400 Oktagon	13.400	88	19	52	60	166	90	97	2,2	7999304
LRBS-FIX 13,400*		88	20	50	60	167	91	97	2,2	
LRBS-FIX 20,000 Oktagon	20.000	100	19,5	60	65	191	98	108	3,6	7999305
LRBS-FIX 20,000*		100	22	60	65	191	100	108	3,7	
LRBS-FIX 32,000 Oktagon	32.000	130	30	72	90	267	134	140	8,0	7999306

Table 3: Dimensioning LRBS-FIX (complete) | * Model in round design - as long as stock lasts Subject to technical alterations

Type LRBS-FIX (Ring)	LC [daN]	A [mm]	B [mm]	C [mm]	D [mm]	E [mm]	F [mm]	G [mm]	K [mm]	N [mm]	T [mm]	weight [kg/pc.]	Ref.-No. ring blank	Ref.-No. ring phos.
LRBS-FIX 8,000 Oktagon	8,000	107	14	69	48	17	18	76	77	19	55	0.4	7910468	7910471
LRBS 8,000*		107	14	69	48	17	18	76	77	19	55	0.9	--	7902251
LRBS-FIX 13,400 Oktagon	13,400	134	19	90	60	23	24	99	100	25	71	0.9	7910469	7910472
LRBS 13,400*		134	20	91	60	23	23	100	101	25	71	0.9	--	7902252
LRBS-FIX 20,000 Oktagon	20,000	152	19.5	97.5	65	28	29	105	106	30	78	1.4	7910470	7910473
LRBS 20,000*		152	22	100	65	28	29	105	106	30	78	1.5	--	7902331
LRBS-FIX 32,000 Oktagon	32,000	204	27	130.5	90	35	37	146	147	37	104	3.2	--	7999300
LRBS 32,000*		204	32	134	90	34	36	146	147	36	102	3.2	--	7993480

Table 4: Dimensioning LRBS-FIX Lashing Ring

Subject to technical alterations

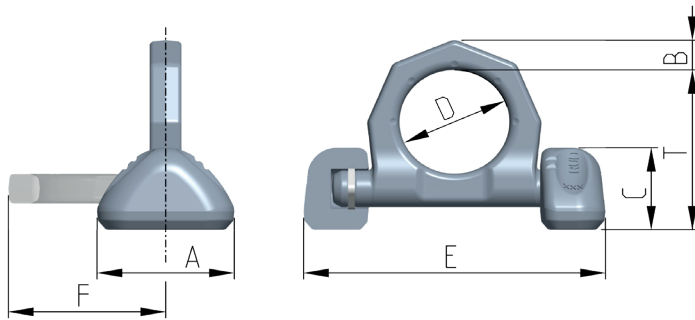

Pic. 3: Dimensioning LRBS-FIX complete

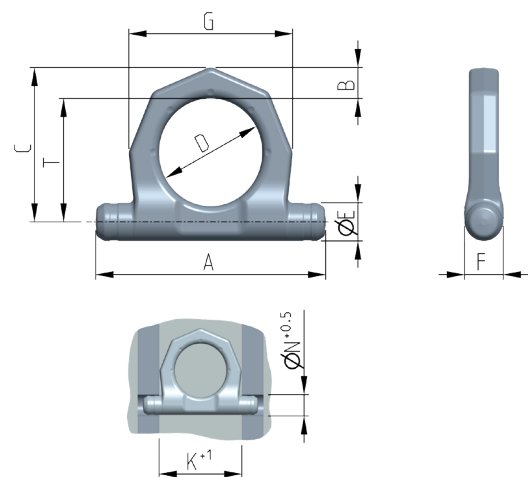

Pic. 4: Dimensioning Lashing Ring (integrated in the design)